

NEW



ÖkoFEN
PELLET HEATING

Pellematic Compact 9kW

Price sheet - Supplementing price list 2016



Available from
15th September 2016

www.oekofen.com

Pellematic Compact

PELLET HEATING BOILER WITH

Vacuum system

Included in delivery: Central heating boiler, pellet burner incl. automatical de-ashing system, boiler control system incl. heating circuit control for 1 HC, suction turbine for vacuum system, operating device Pelletronic Touch



Pellet heating boiler

with ceramic combustion chamber, fully automatic heat exchanger cleaning, integrated back end protection, flue pipe connection at the back or at the top, flow and return lines on the top of the boiler, complete with isolierung and casing

Pellet burner with burner plate, automatic ash removal with integrated ash-box, full burn-back protection, automatic ignition, spigot for direct connection to external combustion air-intake.

Programmable boiler controller

with Pelletronic Touch screen display included in boiler, including all necessary sensors and safety devices, gas flame temperature sensing with differential pressure control, modulating output adjustment, ready to plug and mounted on the boiler

It is possible to control 1 heating circuit and DHW management directly by boiler controller (excl. heating controller). Sensor pack E1575 required.)

Vacuum system

Day hopper with integrated vacuum motor and feed screw.

Operating device Pelletronic Touch

User operation is via Pelletronic Touch colour screen with LAN connection for use with smart devices and PCs.

Available from
15th September 2016

Art.No.	Description	Price excl. VAT.	RC
PES209	Pellematic Compact 9 kW with vacuum system	€ 7.941,-	1

HEATING CIRCUIT CONTROL

Art.No.	Description	Price excl. VAT.	RC
E1575	HC controller f 1HC + DHW mixer Controller for 1 heating circuit + domestic hot water management is integrated in the boiler controller (without separate heating controller) incl. sensor pack and accessories	€ 76,-	4

NOTE: NEW E1575 can only be used in the configuration specified above. For 3 heating circuits, 2 Pelletronic Touch E1392A heating controllers are required!
For heating controllers for 2-6 heating circuits, accumulators, solar and room controllers, see price list 2016 section 'Control, buffer tank and DHW'.

This price sheet is valid from June 2016 and invalidates information in all previous price lists. These prices are exclusive of VAT. We reserve the right to change prices and/or specifications without notice. E&OE.

Please pay attention to technical changes! Used images are illustration picture.

With the appearance of a new price sheet / a new price list this price sheet is no longer valid.

Pellematic Compact equipment

INSTALLATION ALTERNATIVES

1-3 heating circuit assemblies installable directly on the boiler

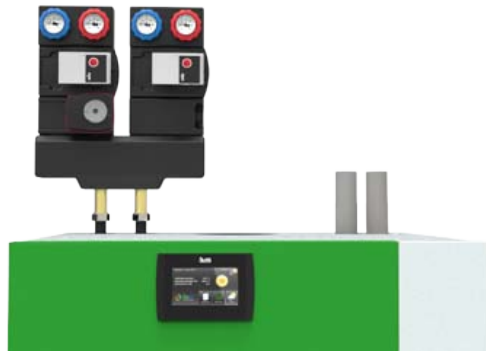

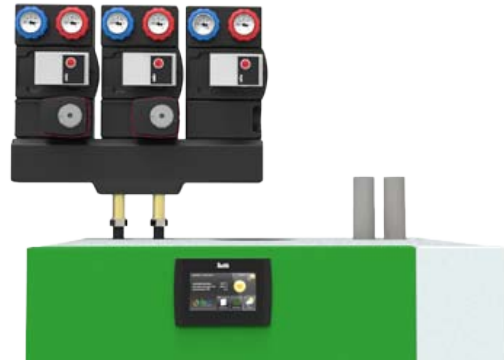

2 heating circuit assemblies
installable directly on the boiler



3 heating circuit assemblies*
installable directly on the boiler

* Special assembly conditions: only possible if the flue gas pipe exit is at the back and if the distance on the left side of the boiler is min. 150 mm.

HYDRAULIC

	Art.No.	Description	Price excl. VAT.	RC
	80470	Buffer loading unit 10-36kW PWM1 Wilo Yonos Para RS25/7.0- PWM1, ready to connect, connection pump unit: 1?, including isolation, shut-off valve & thermometer	€ 280,-	4
	80495	Pump set for mixed HC DN25 Isol Wilo Yonos Para RSTG 15/7.5 90 mm centre distance incl. 3 m cable, secondary-side outlets 1" female thread Mixer with progressive control, KVS value: 2-8 recommended use: up to 18 kW underfloor heating or 32 kW radiators	€ 443,-	4
	80493	Pump set for unmixed HC DN25 Isol Wilo Yonos Para RSTG 15/7.5 90 mm centre distance incl. 3 m cable, secondary-side outlets 1" female thread recommended use: DHW cylinders or up to 32 kW radiators	€ 306,-	4
	80492-1	Universal pump PWM signal cable 3 m, only in conjunction with an unmixed heating circuit assembly for accumulator charging	€ 13,-	4
	80805	Distributor for 2 heating circuits for 2 heating circuits incl. insulation, centre distance: 90 mm Only available in conjunction with heating circuit assembly 80495 or 80493.	€ 105,-	4
	80806	Distributor for 3 heating circuits for 3 heating circuits incl. insulation, centre distance: 90 mm Only available in conjunction with heating circuit assembly 80495 or 80493.	€ 138,-	4
	80807	Universal wall bracket for manifold For boilers with no option to fit pumps directly	€ 36,-	4

* Ordering options only available when ordered with a boiler.



ÖkoFEN
PELLET HEATING

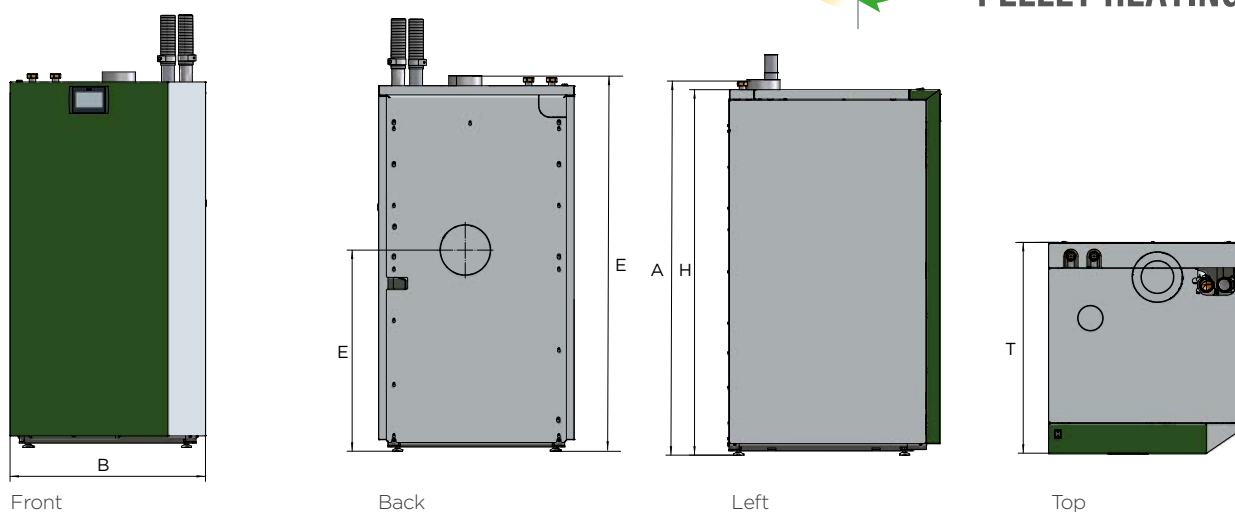

TECHNICAL DATA

Boiler - type		PES209
Boiler - rated power	kW	9
Boiler - partial load	kW	2,7
Boiler efficiency rated power	%	93,5
Boiler efficiency partial power	%	92,6
B - Width - total	mm	762
H - Height of boiler casing	mm	1425
T - Depth of boiler casing	mm	822
Maximum unit dimension	mm	695
Tilted height	mm	1685
Water supply/return - dimensions	Inch	1" IG
A - Height of inlet/return	mm	1449
E - flue gas tube connection height	mm	784 / 1464
Water capacity	l	84
Need of draught rated power/partial load	mbar	0,08/0,03
Available depression flue gas fan	mbar	0,05
Flue gas temperature*	°C	70-140
Flue gas mass flow rated power	kg/h	16,6
Flue gas mass flow partial load	kg/h	5,8
Flue gas volume rated power	m ³ /h	12,2
Flue gas volume partial load	m ³ /h	4,3
Flue gas tube diameter (at the boiler)	mm	132 (inside)
Chimney diameter	per chimney calculation	
Chimney construction	Stainless steel	
Electrical connection	230VAC / 50Hz / 16A / 1760W	

*Adjustment of flue gas temperature to chimney model possible
Please pay attention to technical changes!

ÖkoFEN Forschungs- und
Entwicklungs Ges.m.b.H.
www.pelletsheizung.com

Gewerbepark 1
4133 Niederkappel
Austria

Tel.: +43 (0) 7286 74 50
Fax: +43 (0) 7286 74 50-210
Mail: oekofen@pelletsheizung.at